



# Celebrate LENT 2024

February 18 1st Sunday of Lent

*Holy Spirit, who drives Jesus into the desert, inspire me. Help me remember my oldest dreams and open my eyes to your presence with me today. Help me align my energies with yours.*

How do I want to change this Lent?

I call on \_\_\_\_\_, who knows my heart, to be my companion this week.

February 25 2nd Sunday of Lent

*Creator God, we walk in the midst of new life each spring. Help me see your beauty unfolding.*

- *In people.*
- *In nature.*
- *In music.*
- *In loving acts I witness and perform.*

I commit to praise you at least \_\_\_\_\_ times each day for the beauty I see.

I call on \_\_\_\_\_, who helped me stop and cherish beauty, to be my companion this week.

Make all folds before you begin.

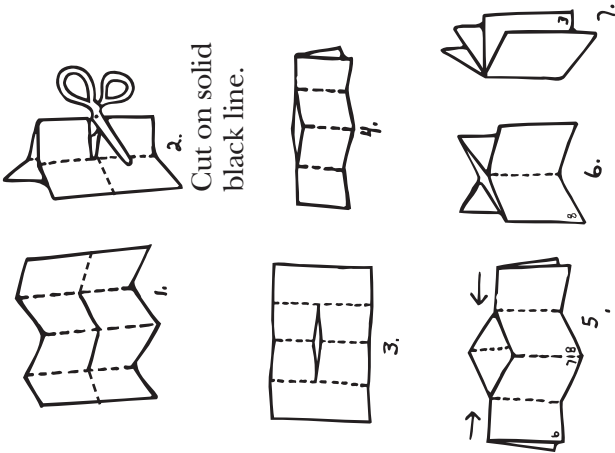

March 3 3rd Sunday of Lent

*Loving God, I crowd my life with things and have-tos. Help me make room to feel your breath in the wind and your voice in my ears. Free me for your friendship.*

I resolve to simplify my life in three ways this week.

- 1
- 2
- 3

I call on \_\_\_\_\_, who always gave me another chance, to be with me.

I have this childhood memory of Holy Week.

March 24 Palm/Passion Sunday

*Jesus, in this holiest of weeks we walk with you in your passion, death, and resurrection. I commit to join the Christian community to celebrate one of these special days. Keep me forever on your path.*

March 10 4th Sunday of Lent

*God, you so loved the world that you sent your Son, to be one of us. Fill me with the light Jesus brings us.*

I will work on forgiving a long-held grudge or a failure eroding my future. I write my resolution here:

I call on \_\_\_\_\_, who forgave me, to speak to my heart.

March 17 5th Sunday of Lent

*Jesus, you taught us to see our own sins and failures, before we criticize and condemn others. Keep me in your love and friendship.*

I will work on appreciating the friendships that sustain me every day. I will say thank you—

- to those closest to me.
- to coworkers.
- to people who show me kindness.

I call on \_\_\_\_\_, who showed me how to be a friend, to walk with me this week.